

# ZOETROPES

1. You are provided with a black correx disc to build your zoetrope.
2. Stick the zoetrope template onto black card and carefully cut around the shape.

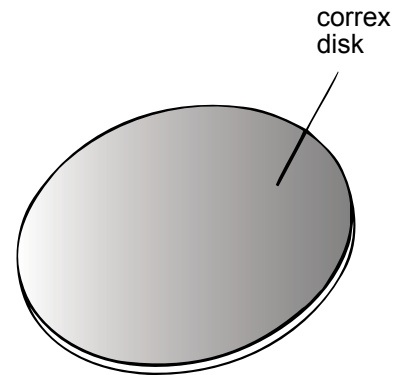

3. Glue flap A to tail A and flap B to tail B.

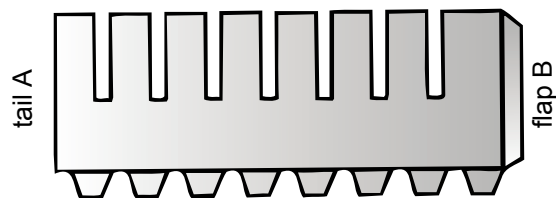
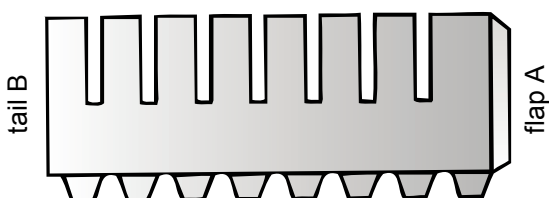

4. You should be left with a drum like this. Fold the bottom tabs inward and stick them to the under side of the correx disc. Make sure that the black card is facing outwards.
5. Push a small wooden wheel onto one end of a peice of dowel.
6. Thread a straw on to the dowel.
7. Push a large wooden wheel onto the other end of the stick.
8. Push a little of the stick up through the larger wheel and the base of the black disc and glue the disc firmly on to the wooden wheel.

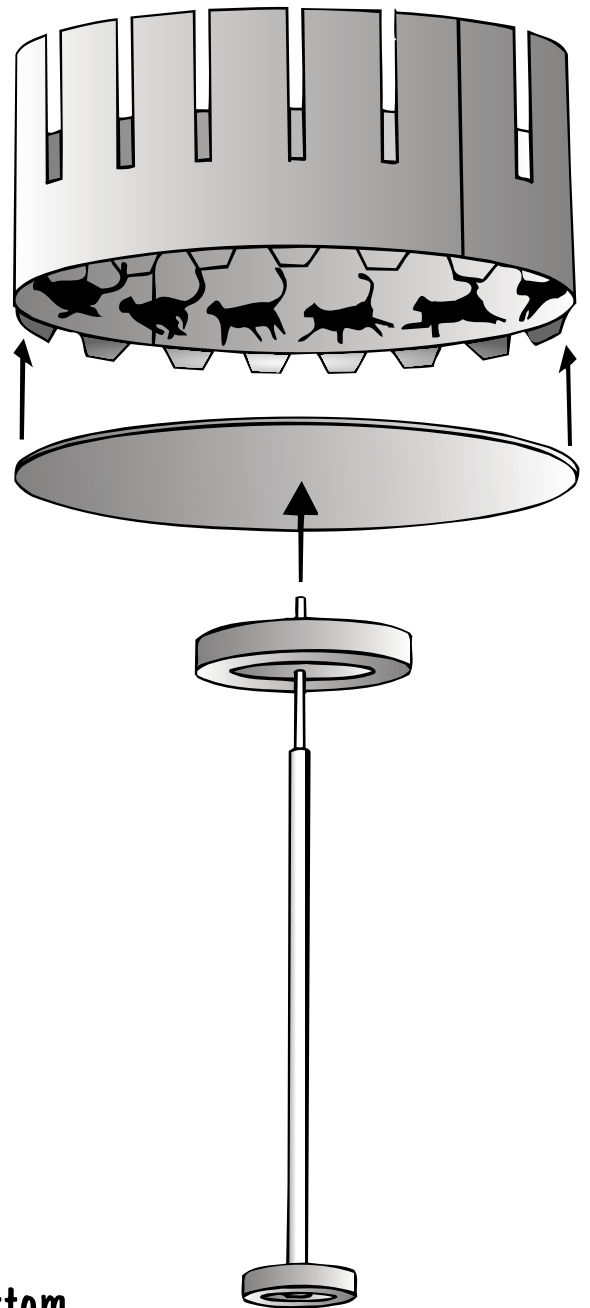

To use the zoetrope hold the straw, spin the bottom wheel and view through the slits.

### IDEAS TO INVESTIGATE

- What do you see when you spin the zoetrope?
- Does the bird's wing move faster or slower when you change the speed?
- What happens if you spin the zoetrope the other way?
- Can you produce your own zoetrope design?
- Can you power it with a solar panel?

# ACTIVITY SHEET

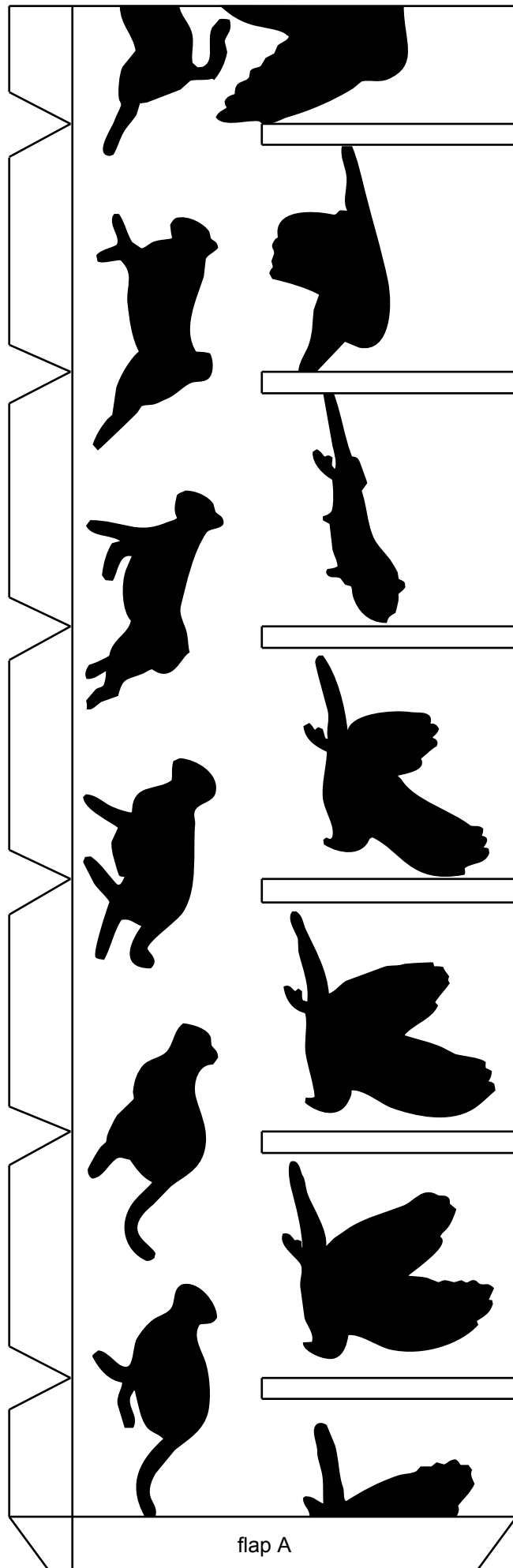
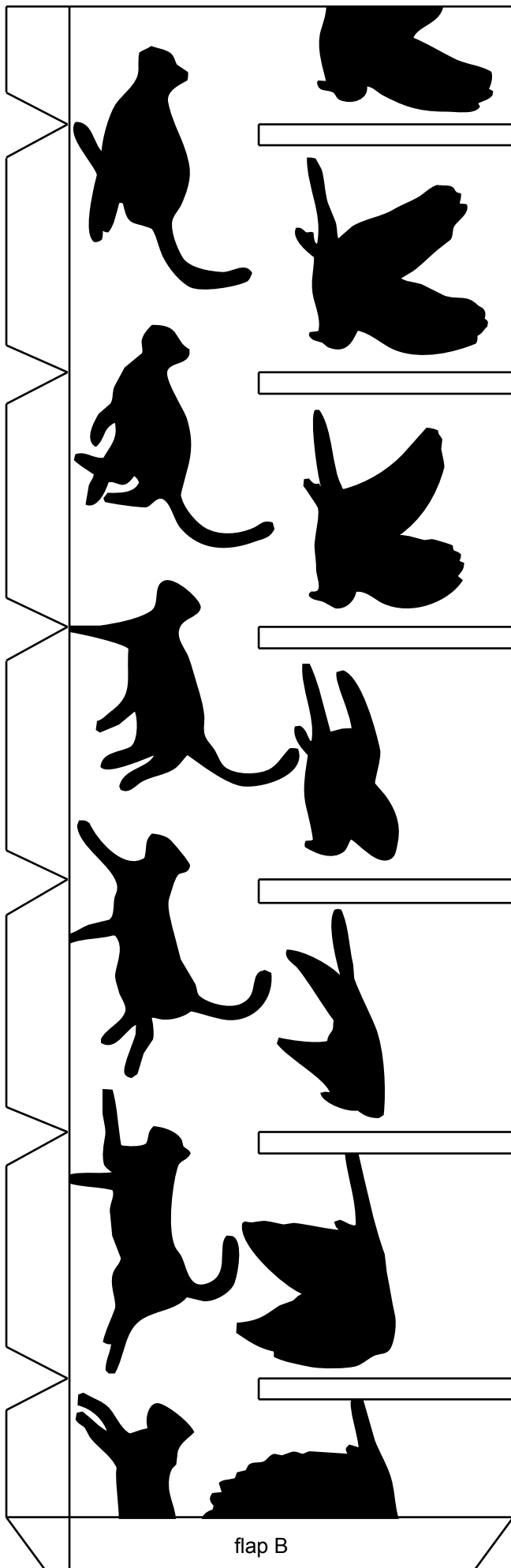

# ACTIVITY SHEET

